

Special Solutions

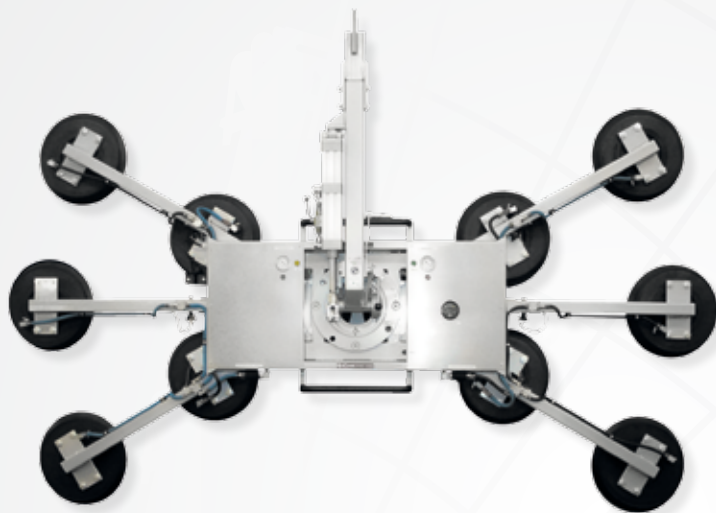

Vacuum Lifting



More information: www.uplifter.de

DSZ 900

Wired remote control

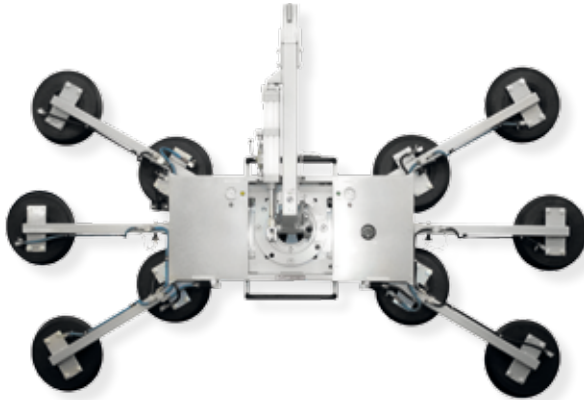

Technical Data	
Vacuum System	2-circuit-system
Lifting Capacity	up to 900 kg
Vacuum Cups	6 8 10 12
Tare Weight	90 kg 100 kg 110 kg 120 kg
Height	min. 180mm
Operating Temperature	-1° up to 35° C
Operating Time	8 hours
Highlight	lowering cylinder
Accessory	transport
Optional	wireless remote control

Features

- » Manual tilting 90°
- » Manual turning 360°
- » Off-grid motor with 12 volts rechargeable battery
- » LED Battery-Status Display
- » DIN EN 13155
- » Individual arrangement of the spring mounted vacuum cups(Ø330mm) without tools
- » Optic / acoustic warning devices (low vacuum warning buzzer)

DSMH2-12V

Wired remote control



Technical Data	
Vacuum System	2-circuit-system
Lifting Capacity	up to 1.200 kg
Vacuum Cups	16 (Ø 330 mm)
Tare Weight	280 kg
Height	min. 280mm
Operating Temperature	-1° up to 35° C
Operating Time	8 hours
Accessory	incl. transport dolly
Optional	wireless remote control

Features

- » Hydraulic tilting 90°
- » Motorized turning 360°
- » With wired remote control
- » Off-grid motor with 12 volts rechargeable battery
- » DIN EN 13155
- » Extensions for wide elements
- » Optic/acoustic warning devices (low vacuum warning buzzer)

DSZ 2000

Wired remote control

Technical Data

Vacuum System	4-circuit-system
Lifting Capacity	up to 700 kg
Vacuum Cups	12
Tare Weight	700 kg
Height	min. 430
Operating Temperature	-1° up to 35° C
Operating Time	8 hours
Dimensions	3160 x 1850 mm
Optional	wireless remote control



Features

- » Hydraulic tilting 90°
- » Motorized turning 360°
- » Off-grid motor with 12 volts rechargeable battery
- » With wired remote control
- » DIN EN 13155
- » Optic/acoustic warning devices (low vacuum warning buzzer)

Your contact person:



UPLIFTER GmbH & Co. KG

Oberaich 5 | D-92543 Guteneck | Tel.: +49 (0) 94 33 / 2 04 99-0 | Fax +49 (0) 94 33 / 2 04 99-29 | info@uplifter.de
www.uplifter.de