

Vacuum Lifters (Suction Discs)

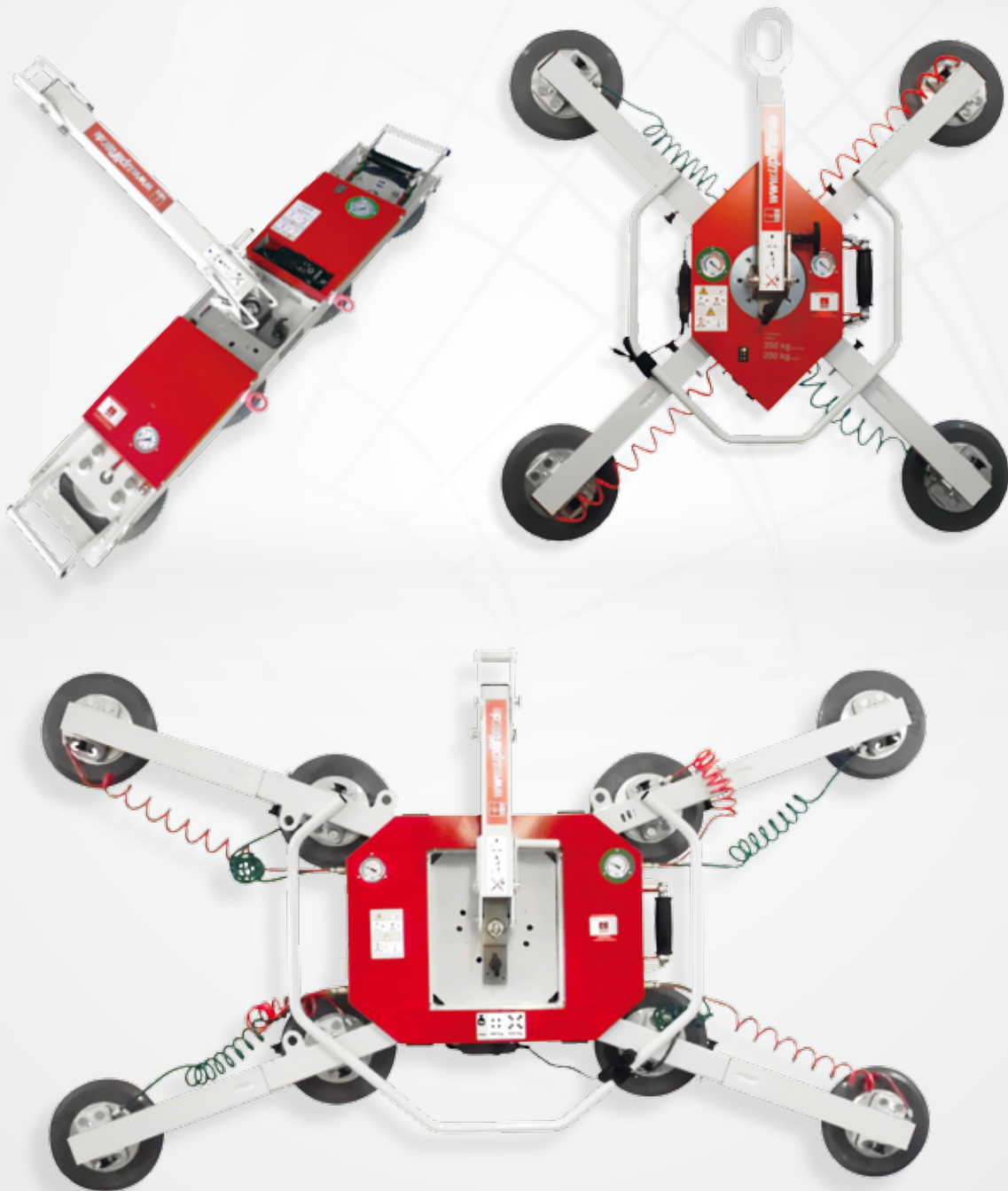

Vacuum Lifting



More information: www.uplifter.de

Suction Disc UPG 350-2

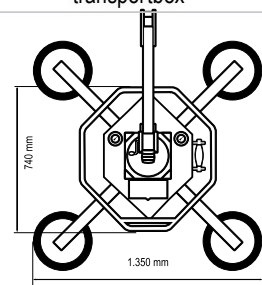
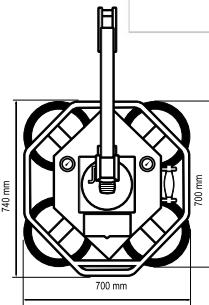
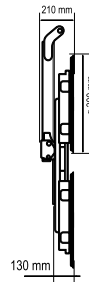
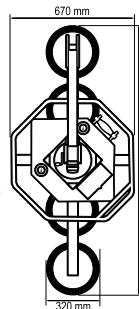

Technical Data

Vacuum System	2-circuit-system
Lifting Capacity	up to 350 kg
Vacuum Cups	4
Tare Weight	43 kg
Height	min. 210 mm
Operating Temperature	0 up to 40°C
Operating Time	8 hours
Accessory	incl. wooden transportbox

Features

- » Manual tilting 90°
- » Manual turning 360°
- » Silicon-free vacuum cups (Ø 300mm)
- » Off-grid Motor with 12 volt rechargeable battery
- » Integrated vacuum-reserve tank
- » Individual Arrangement of the spring mounted vacuum Cups
- » Vacuum Cups adjustable without tools
- » DIN 13155
- » Optic/acoustic warning devices (low Vacuum warning buzzer)

Suction Disc UPG 450

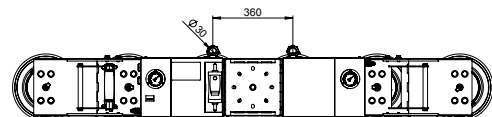
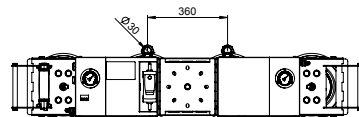
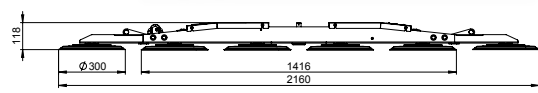
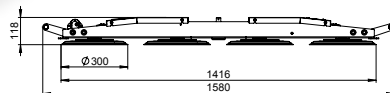
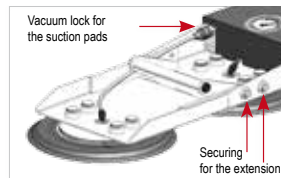
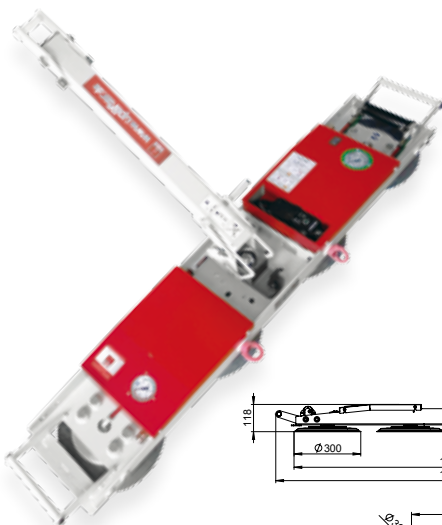

Technical Data

Vacuum System	2-circuit-system
Lifting Capacity	up to 450 kg
Vacuum Cups	4 / 6
Tare Weight	47 kg / 57 kg
Height	min. 118 mm without load-arm min. 179 mm with load-arm
Operating Temperature	0 up to 40°C
Operating Time	8 hours
Accessory	incl. wooden transportbox
Highlight	removable load-arm



Suction Disc UPG 600-2

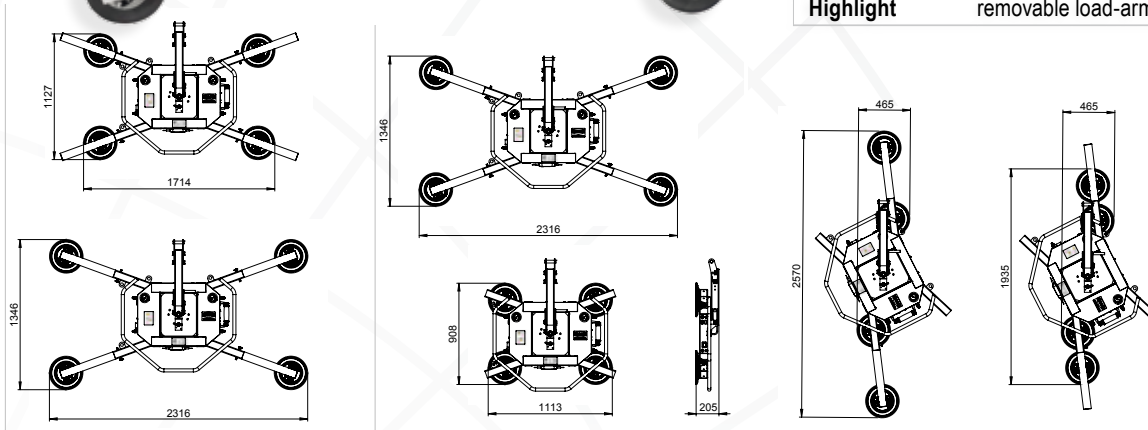
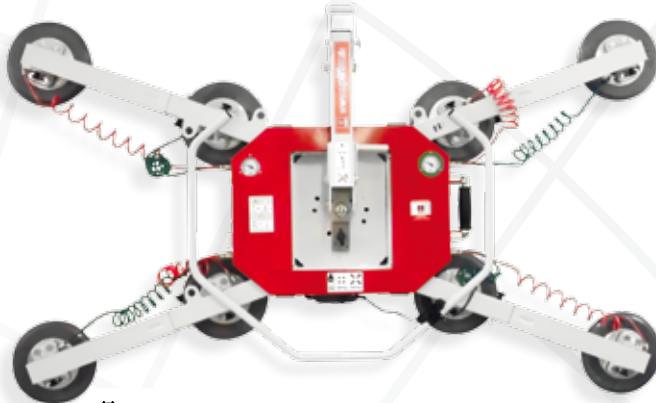

Technical Data	
Vacuum System	2-circuit-system
Lifting Capacity	up to 600 kg
Vacuum Cups	4 / 6 / 8
Tare Weight	70 kg / 80 kg / 89 kg
Height	min. 139 mm without load-arm min. 205 mm with load-arm
Operating Temperature	0 up to 40°C
Operating Time	8 hours
Accessory	incl. wooden transportbox
Highlight	removable load-arm

Features

- » Manual tilting 90°
- » Manual turning 360°
- » Silicon-free vacuum cups (Ø 300mm)
- » Off-grid Motor with 12 volt rechargeable battery
- » Integrated vacuum-reserve tank
- » Individual Arrangement of the spring mounted vacuum Cups
- » Vacuum Cups adjustable without tools
- » DIN 13155
- » Optic/acoustic warning devices (low Vacuum warning buzzer)

Equipment



Foam-rubber vacuum cups



UPT 200



Mount Extensions



Wooden Transportbox

Your contact person:

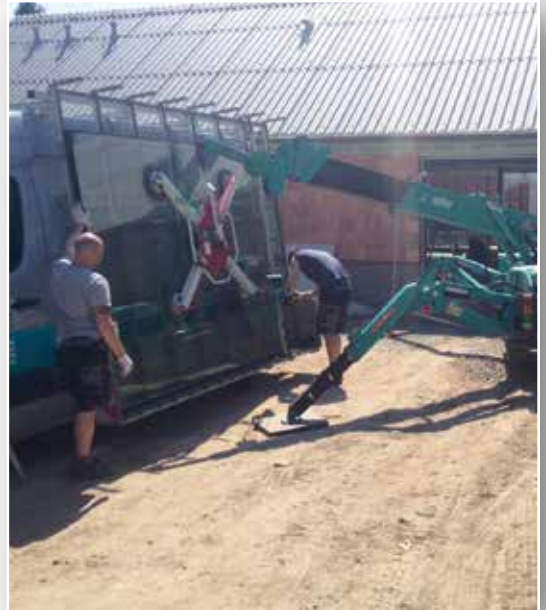

UPLIFTER GmbH & Co. KG

Oberaich 5 | D-92543 Guteneck | Tel.: +49 (0) 94 33 / 2 04 99-0 | Fax +49 (0) 94 33 / 2 04 99-29 | info@uplifter.de
www.uplifter.de