

# Glass transport devices



UPT- and UPL-Series



## UPT 150 Racelift 2.0

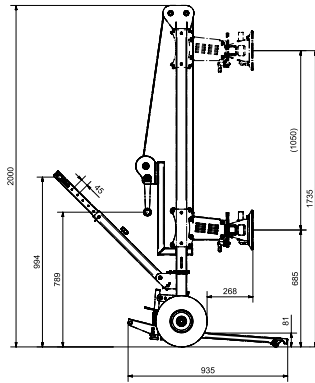

Technical data	
<b>Vacuum system</b>	Hand held vacuum cup
<b>Lifting capacity</b>	up to 150 kg
<b>Vacuum pads</b>	2
<b>Tare weight</b>	56 kg
<b>Propulsion</b>	manual
<b>Tires</b>	PU (Ø 300mm)
<b>Width</b>	810 mm

### Features

- » Lifts elements up to 150kg
- » 1-man-control
- » Glass rotation 360°
- » Slip resistant handle
- » Dismountable without tools (3 components)
- » Rotating boom 90°

## UPT 180



## UPL 300



## UPL 500



Technical data	
<b>Lifting capacity</b>	up to 180 kg
<b>Tare weight</b>	11 kg
<b>Dimensions</b>	490 x 740 x 1.100 mm
<b>Tires</b>	Pneumatic tires (Ø 260 mm)
<b>Highlight</b>	with integrated hand vacuum cup

Technical data	
<b>Lifting capacity</b>	up to 300 kg
<b>Tare weight</b>	8,4 kg
<b>Dimensions</b>	490 x 740 x 1.100 mm
<b>Tires</b>	Pneumatic tires (Ø 260 mm)
<b>Highlight</b>	made of Aluminium

Technical data	
<b>Lifting capacity</b>	up to 500 kg
<b>Tare weight</b>	12,9 kg
<b>Dimensions</b>	950 x 370 x 260 mm
<b>Tires</b>	Pneumatic tires (Ø 260 mm)
<b>Highlight</b>	made of Aluminium



## UPT 600

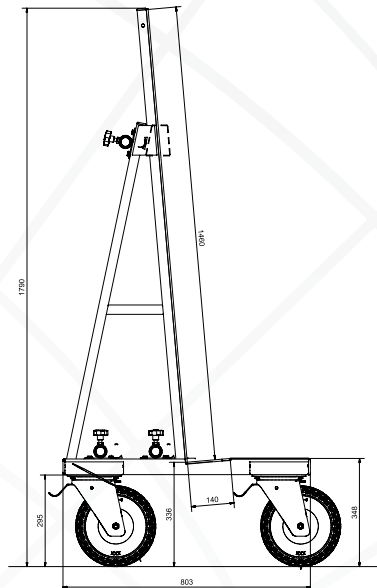

Technical data	
<b>Lifting capacity</b>	up to 600 kg
<b>Tare weight</b>	63 kg
<b>Dimensions</b>	2.000 x 803 x 1.790 mm
<b>Element size</b>	max. 6.000 x 3.500 mm
<b>Element thickness</b>	up to 140 mm
<b>Tires</b>	Air (Ø 300mm)

### Features

- » Dismountable without tools
- » Transport possible by car
- » 1-man-control
- » Wheels single fixable

## UPT 800

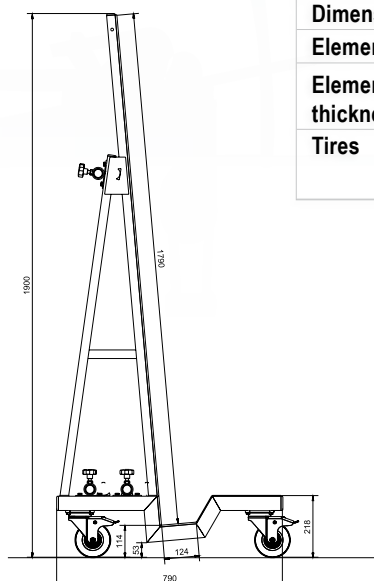

Technical data	
<b>Lifting capacity</b>	up to 800 kg
<b>Tare weight</b>	63 kg
<b>Dimensions</b>	2.000 x 803 x 1.790 mm
<b>Element size</b>	max. 6.000 x 3.500 mm
<b>Element thickness</b>	up to 140 mm
<b>Tires</b>	Heavy duty (Ø 160mm)

Your contact person:



**UPLIFTER GmbH & Co. KG**

Oberaich 5 | D-92543 Guteneck | Tel.: +49 (0) 94 33 / 2 04 99-0 | Fax +49 (0) 94 33 / 2 04 99-29 | [info@uplifter.de](mailto:info@uplifter.de)  
[www.uplifter.de](http://www.uplifter.de)